



# Fire Barrier Duct Wrap 20A

## Commerical Kitchen Grease Duct Fire Protection System

### Product Data and Installation Instructions



**NFPA 96**  
Compliance  
1998 Edition



Complies with  
**International  
Mechanical Code**

Complies with  
**Uniform  
Mechanical Code**

## 1. Product Description

3M™ Fire Barrier Duct Wrap 20A is a fire resistant wrap consisting of a patented inorganic blanket encapsulated with a scrim-reinforced foil. It is used to fire rate commercial kitchen grease ducts and is a proven alternative to 1 or 2 hour fire resistant rated shaft enclosures. This non-asbestos wrap contains a safer fiber construction\* and installs easily because of its high flexibility and strength. 3M Fire Barrier Duct Wrap 20A is a two-layer fire resistant wrap system that has passed the ICBO AC101 internal test which simulates a grease duct fire. With its excellent insulating capabilities, it is an ideal choice for tight spaces because it protects combustible constructions at zero clearance. 3M Fire Barrier 1000 N/S, 1003 S/L or 2000+ Silicone Sealants used in combination with 3M Fire Barrier Duct Wrap 20A provide an effective firestop when the duct penetrates fire rated walls and floors.

### Features

- Listed to pass the internal grease duct fire test, ICBO AC101
- Zero clearance to combustibles for congested spaces
- High flexibility for installation ease
- Foil encapsulated with unique center overlap seam for blanket strength, protection and less dust
- Safer fiber construction\*

\*Has been demonstrated to be soluble in the lungs according to EU guidelines 67/548/EWG, Note Q for bio persistence.

## 2. Applications

3M Fire Barrier Duct Wrap 20A is an ideal fire resistive enclosure for commercial kitchen grease ducts. It is a proven performance alternative to a 1 or 2 hour fire resistant rated shaft enclosures and provides zero clearance to combustible construction at overlap or collar. 3M Fire Barrier 1000 N/S, 1003 S/L or 2000+ Silicone Sealant is used in combination with 3M Fire Barrier Duct Wrap 20A to firestop the duct when the duct penetrates fire rated floors and walls.

## 3. Availability

Product	Unit	Size	Units/ ctn.	Wt./ ctn.
3M Fire Barrier Duct Wrap 20A	Roll	2 in. x 24 in. x 20 ft. (50 mm x 60.9 cm x 609 cm)	1	70 lbs. 31 kg
3M Fire Barrier Duct Wrap 20A	Roll	2 in. x 48 in. x 20 ft. (50 mm x 121 cm x 609 cm)	1	140 lbs. 63 kg
3M Fire Barrier Duct Wrap 20A Collar	Roll	2 in. x 6 in. x 20 ft. (50 mm x 152 cm x 609 cm)	4	70 lbs. 31 kg

## 4. Typical Physical Properties

Blanket Color: gray/green  
Weight: 1.83 lbs./sq. ft. (8.93 kg/sq. m)

## 5. Performance

3M Fire Barrier Duct Wrap 20A has been tested in accordance with the following:

ASTM C 411  
ASTM C 518  
ASTM E 84  
ASTM E 119  
ASTM E 136  
ASTM E 814  
ICBO AC101 Internal

Surface Burning Characteristics (ASTM E 84)

Foil Encapsulated Blanket:

Flame Spread: 0  
Smoke Developed: 0

Blanket:

Flame Spread: 0  
Smoke Developed: 0

## Thermal Conductivity

Temperature °F (°C)	btu•in./(hr.•ft²•F)
500 (260)	0.417
1000 (537)	0.922
1500 (815)	1.69
1800 (982)	2.27

For technical data and properties of 3M Fire Barrier 1000 N/S, 1003 S/L and 2000+ Silicone Sealants see separate product data sheets available from your 3M representative.

## Grease Duct Listings

Fire Resistive Rating	Enclosure System	Omega Point Lab. Design Nos.	
		Duct System	Through-Penetration System
1 or 2 hours	2 layers of 3M Fire Barrier Duct Wrap 20A, 3 in. (76 mm) perimeter and longitudinal overlaps	GD 531 F	FS 557 W FS 558 F FS 559 W FS 560 F FS 561 F FS 562 W FS 563 W

## Code Compliance

3M Fire Barrier Duct Wrap 20A complies with requirements of the following codes:

NFPA 96, 1998 Edition  
Uniform Mechanical Code Section 507.6  
International Mechanical Code Section 506.3.11  
Uniform Building Code Section 711  
ICBO ES Evaluation Report No. 5907

This is only a partial list of code compliance. For the latest code and approval information go to [www.3m.com/firestop](http://www.3m.com/firestop) or speak to your authorized 3M distributor or sales representative at (800) 328-1687.

## 6. Installation Techniques

3M Fire Barrier Duct Wrap 20A system should be installed in accordance with the following installation instructions.

## Material and Equipment

- 3M Fire Barrier Duct Wrap 20A blanket, 2 in. (50 mm) thick, 24 in. (60 cm) or 48 in. (121 cm) wide, 20 ft. (609 cm) standard length. The 48 in. (121 cm) wide blanket helps to minimize waste.
- Aluminum foil tape.
- Minimum 3/4 in. (19 mm) wide filament tape.
- Carbon steel or stainless steel banding material, minimum 1/2 in. (12,7 mm) wide, minimum 0.015 in. (0,38 mm) thick, with steel banding clips.
- Hand banding tensioner, crimping tool, and banding cutter.
- Minimum 12 gauge copper-coated steel insulation pins; galvanized steel speed clips, minimum 1-1/2 in. (38 mm) square or 1-1/2 in. (38 mm) dia. round, or equivalent sized insulated cup-head pins; capacitor discharge stud gun.
- Access door hardware: four galvanized steel thread rods, 1/4 in. (6 mm) diameter by 4-1/2 in. to 5 in. long (114 mm to 127 mm) with 1/4 in. (6 mm) wing nuts and 1/4 in. (6 mm) washers; 4 in. (102 mm) long steel hollow tubing to fit threaded rods.
- Minimum 4.0 lb. (1,8 kg) density mineral wool or scrap pieces of 3M Fire Barrier Duct Wrap 20A blanket
- 3M Fire Barrier 1000 N/S, 1003 S/L or 2000+ Silicone Sealant.

## Storage

The 3M Fire Barrier Duct Wrap 20A and 3M Fire Barrier 1000 N/S, 1003 S/L and 2000+ Silicone Sealants must be stored in a dry warehouse environment. Pallets should not be stacked.

**Preparatory Work:** 3M Fire Barrier Duct Wrap 20A is installed with common tools, such as knives, banders and capacitor discharge guns for applying insulation pins. In order to install the duct firestop system, the surfaces of all the openings and penetrating items need to be clean, dry, frost free and free of dust.

**Method:** To minimize waste, 3M Fire Barrier Duct Wrap 20A material should be rolled out tautly before measuring. General instructions for installing the 3M Fire Barrier Duct Wrap 20A includes a two-layer wrap construction applied directly to the duct. The first layer or interior wrap of 3M Fire Barrier Duct Wrap 20A shall be cut to a length sufficient to wrap completely around the perimeter of the duct, plus provide an overlap of not less than 3 in. (76 mm). Aluminum foil tape is used to seal cut edges of the blanket. Use filament tape to temporarily hold first layer blanket in place. The second layer is applied over the first layer using one of the following methods. Banding is only applied to the exterior layer.

**There are three (3) approved installation techniques for installing the 3M Fire Barrier Duct Wrap 20A (See Figures 1A-1D and Figures 2A-2D):**

## 1. Telescoping 3 in. (76 mm) Overlap Wrap

With the telescoping overlap wrap method, each blanket overlaps one adjacent blanket, and each blanket has one edge exposed and one edge covered by the next blanket as shown in Figure 1A and 1B. The visible edges of the perimeter overlaps all point in the same direction. The next adjacent interior wrap of 3M Fire Barrier Duct Wrap 20A shall be cut to completely wrap around the perimeter of the duct with enough excess to provide an overlap of not less than 3 in. (76 mm). A minimum 3 in. (76 mm) longitudinal overlap onto the previous adjacent wrap is required on both layers.

The second layer or exterior wrap of 3M Fire Barrier Duct Wrap 20A should be cut to sufficient length to wrap completely around the perimeter of the interior wrap with sufficient excess to provide an overlap of not less than 3 in. (76 mm). The 3M Fire Barrier Duct Wrap 20A to be installed as the exterior layer shall be cut, if needed, and properly located to ensure that the longitudinal overlap joints of the exterior layer of blanket are staggered 10-1/2 in. (26,7cm) from those of the interior layer. Aluminum foil tape is used to seal any cut edges of the blanket.

## 2. Checkerboard 3 in. (76 mm) Overlap Wrap

With the 3 in. (76 mm) checkerboard overlap wrap method, blankets with both edges exposed alternate with blankets with covered edges, as shown in Figure 1C. The visible edges of the perimeter overlaps alternate their directions and appear on every other blanket.

## 3. Butt Joint With Collar

With the butt joint and collar overlap method, adjacent blankets are butted tightly together and 6 in. (152 mm) wide collar of 3M Fire Barrier Duct Wrap 20A is centered over the joint, overlapping each blanket by 3 in. (76 mm) as shown in Figure 1D.

In all three overlap techniques the perimeter overlap can occur at any location on the duct.

The blanket is mechanically attached to the duct by steel banding or by welded insulation pins and clips for all three installation methods listed above.

## For Banding Only (See Figures 1A to 1D)

Filament tape can be used to temporarily hold the blanket in place until the banding is applied. The steel banding is applied around the duct 1-1/2 in. (38 mm) from each edge of the blanket, and 10-1/2 in. (26,7 cm) maximum centers. The banding is placed around the exterior layer of material and tightened so as to sufficiently hold the 3M Fire Barrier Duct Wrap 20A in place against the duct, compressing the foil but not cutting the foil.

Additional Pinning to Prevent Sagging of the Wrap:  
For Ducts 24 in. (60 cm) and larger in width, additional pins are needed to support the blanket on the bottom horizontal surface and on the outside face of a vertical duct run. Space pins a maximum of 10-1/2 in. (26,7 cm) apart in the direction of the blanket width, and a maximum of 12 in. (30 cm) apart in the direction of the blanket length. Refer to paragraph below for more information on Mechanical Fastening with Pins.

### **For Mechanical Fastening with Pins Only (See Figure 2A to 2D)**

Insulation pins are welded to the duct in the centers of the overlaps a minimum of 1-1/2 in. (38 mm) from each edge of the blanket, and spaced a maximum of 8 in. (27 mm) on center along perimeter overlap, and a maximum of 10-1/2 in. (38 mm) on center along longitudinal overlaps. The blanket is impaled over the pins and held in place by galvanized speed clips. Insulation pins that extend beyond the blanket wrap shall be turned down to eliminate sharp points. Insulated cup-head pins can be used at the same spacing requirements of the insulation pins.

**NOTE:** Support hangar systems do not need to be wrapped provided the hangar rods are at least a minimum of 3/8 in. (9,53 mm) diameter and spaced a maximum of 60 in. (152,4 cm) on center along the length of the duct. Use a minimum 2 in. x 2 in. x 1/4 in. (50 mm x 50 mm x 6,35 mm) steel angle steel support channel or SMACNA equivalent support system.

### **Access Door Installation (See Figure 3)**

Four galvanized steel threaded rods, 1/4 in. diameter (6,35 mm) by 6-1/2 in. to 7 in. long (165 mm to 177 mm) are welded to the duct at the corners of the door opening. Four steel tubes, each 5 in. to 7 in. (127 mm to 165 mm) long, are placed over the rods to act as protection for the 3M Fire Barrier Duct Wrap 20A when fastening the door. Four insulation pins are welded to the door panel for installation of the blanket. One layer of 3M Fire Barrier Duct Wrap 20A is cut so as to be approximately the same size as the access door panel and impaled over the insulation pins.

*It is essential that this layer fit tightly against the wrap surrounding the access door opening with no through openings.* A second layer of 3M Fire Barrier Duct Wrap 20A is cut so as to overlap the first layer by a minimum of 1 in. (25 mm) on all sides. A third layer of 3M Fire Barrier Duct Wrap 20A is cut to overlap the second layer by 1 in (25 mm) on all sides. The layers are impaled over the welding pins and all layers are

locked in place with galvanized speed clips. Pins that extend beyond the outer layer of 3M Fire Barrier Duct Wrap 20A shall be turned down to avoid sharp points on the door.

The insulated door panel is placed over the threaded rods and held in place with washers and wing nuts. The details are shown in Figure 3.

### **Penetrations (See Figures 4A to 4D)**

When the duct penetrates a fire rated wall, ceiling or floor, an approved firestop system must be employed. Figures 4A to 4D illustrate typical conditions.

To firestop the wrapped duct, follow the installation parameters detailed in the following Omega Point Laboratories, Inc. systems:

FS 557 W, FS 558 F, FS 559 W, FS 560 F, FS 561 F, FS 562 W, FS 563 W.

### **Other Applications**

Refer to Figures 5, 6, 7, 8 and 9 for additional typical conditions.

## **7. Maintenance**

No maintenance is required when installed in accordance with the 3M Installation Instructions. Once installed, if any section of the 3M Fire Barrier Duct Wrap 20A is damaged so that the blanket is damaged, the following procedures will apply:

- The damaged section should be removed by cutting the steel banding or removing the clips holding it in place.
- A new section of the same dimension should be cut from a roll of 3M Fire Barrier Duct Wrap 20A, either 24 in. (60,9 cm) or 48 in. (121 cm) wide.
- The new section should be placed and fitted ensuring the same overlap that existed previously.
- The steel banding should be placed around the material and tensioned so as to sufficiently hold the 3M Fire Barrier Duct Wrap 20A in place.
- If the blanket has not been damaged but the foil has ripped, seal the rip with aluminum foil tape.

## **8. Purchase Information**

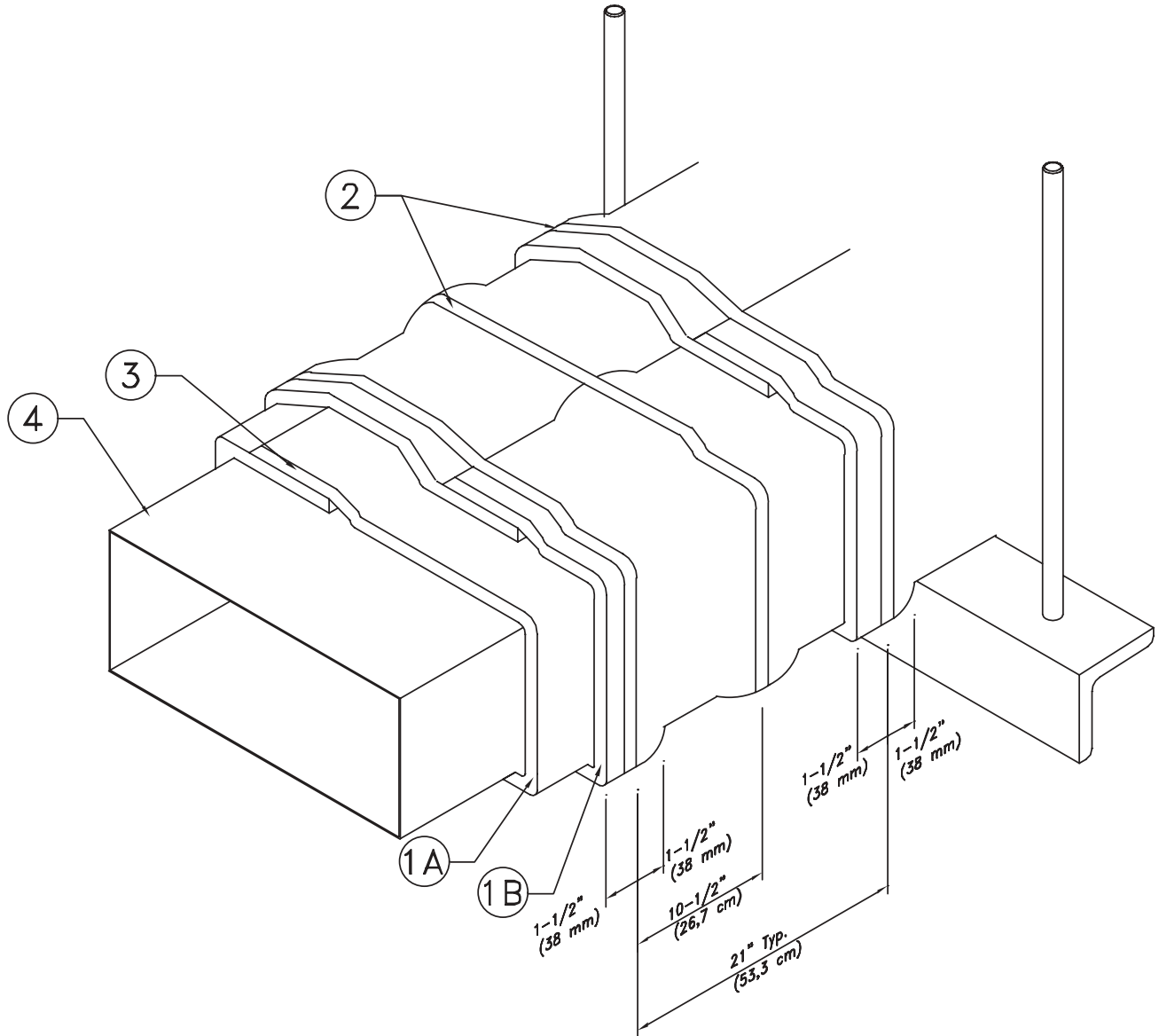
3M Fire Barrier products are available through a network of nationwide distributors. For information on where to buy, go to [www.3m.com/firestop](http://www.3m.com/firestop).

## **9. Safe Handling Information**

**Consult Material Safety Data Sheet prior to handling and disposing of 3M Fire Barrier Duct**

**Figure 1A**  
**3M Fire Barrier Duct Wrap 20A**  
**Commercial Kitchen Grease Duct Systems**  
**1 or 2 Hour Shaft Alternative Zero Clearance to Combustibles**  
**Telescoping Wrap Technique With Banding For Ducts 24 inches (60,9 cm) or Less**

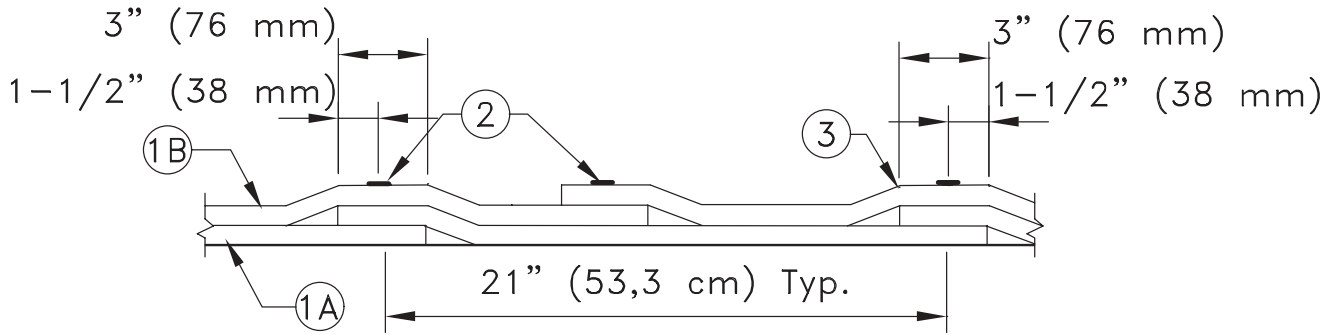
Wrap 20A.



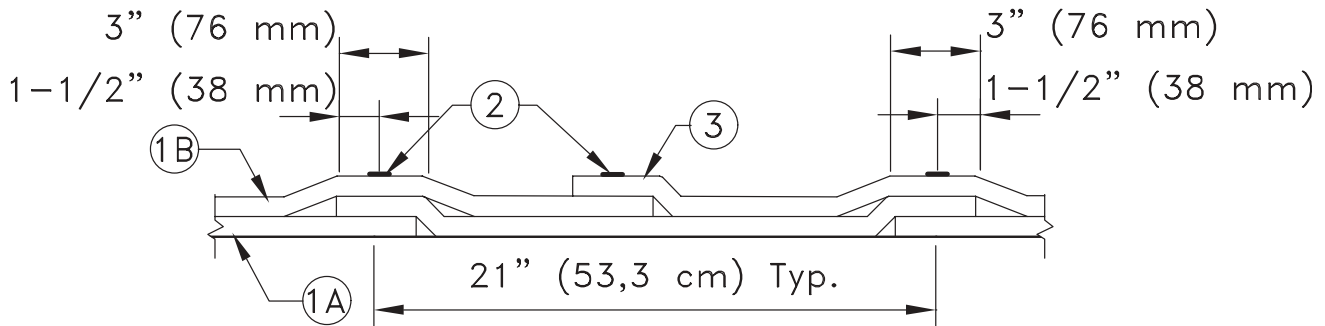
1A.	First Layer 3M Fire Barrier Duct Wrap 20A
1B.	Second Layer 3M Fire Barrier Duct Wrap 20A
2.	Steel Banding 1/2 in. (13 mm) Wide Min. Typical
3.	3 in. (76 mm) Min. Longitudinal Overlap
4.	3 in. (76 mm) Min. Perimeter Overlap

System integrity is limited by quality of installation.

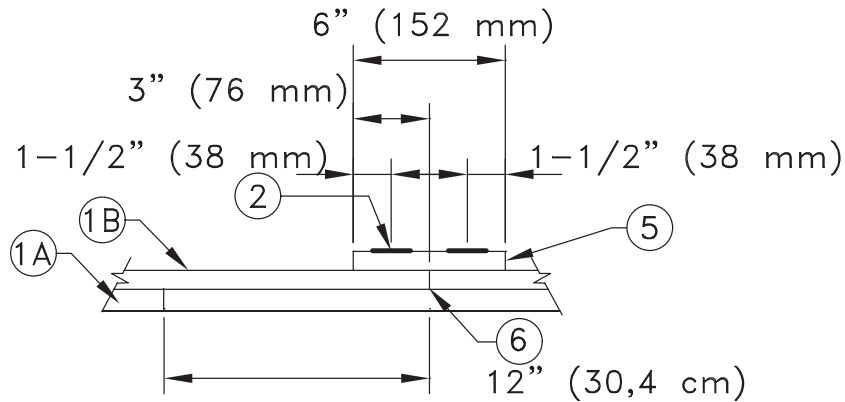
**Figure 1B Telescoping Overlap Wrap Option  
Cross Sectional View**



**Figure 1C Checkerboard Overlap Wrap Option  
Cross Sectional View**



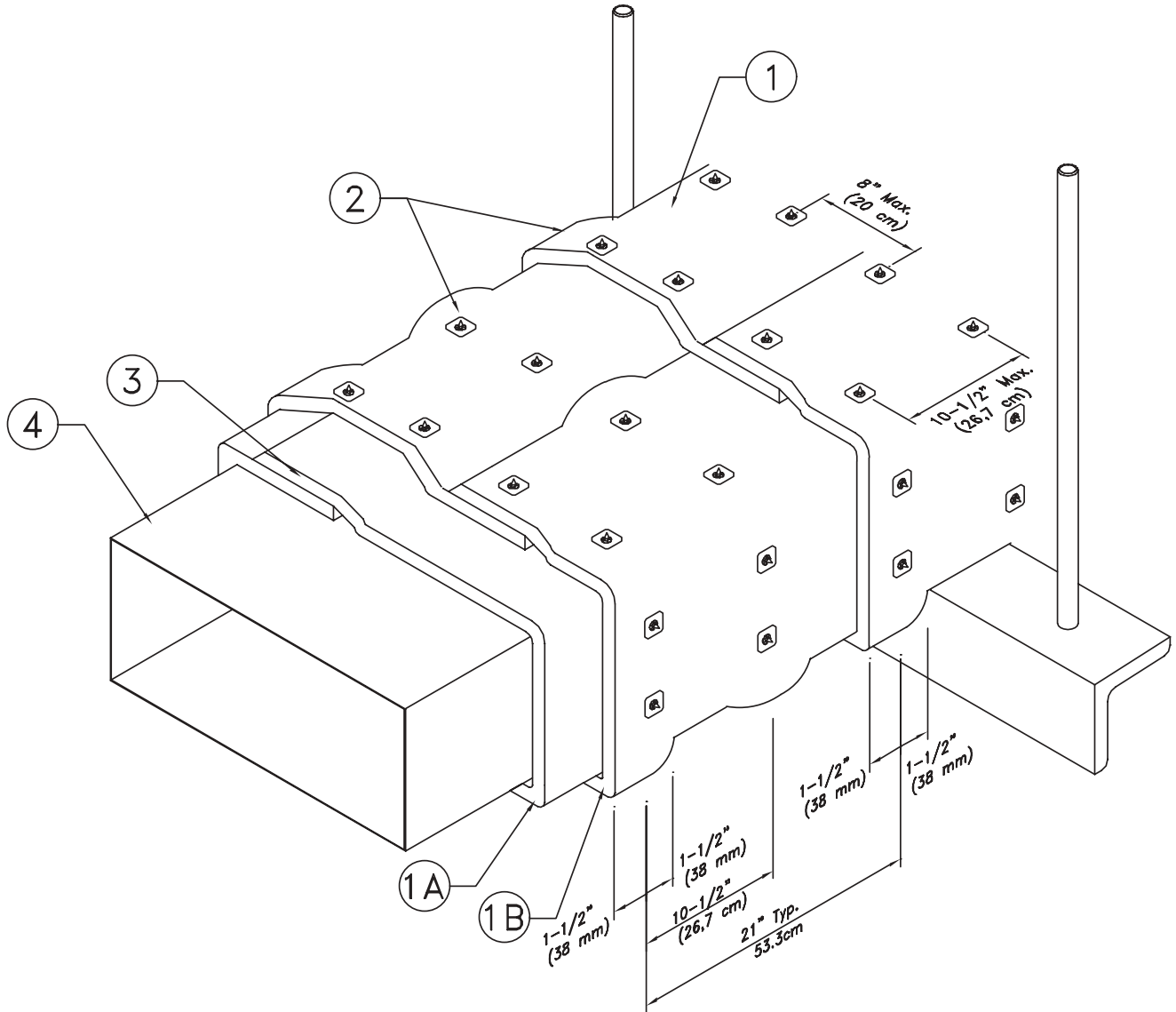
**Figure 1D Butt Joint With Collar Option  
Cross Sectional View**



1A.	First Layer 3M Fire Barrier Duct Wrap 20A
1B.	Second Layer 3M Fire Barrier Duct Wrap 20A
2.	Steel Banding 1/2 in. (13 mm) Wide Min. Typical
3.	3 in. (76 mm) Min. Longitudinal Overlap
4.	3 in. (76 mm) Min. Perimeter Overlap
5.	6 in. (152 mm) Wide Collar: Prefabricated 3M Fire Barrier 20A Collar
6.	Firmly Butted Joint

System integrity is limited by quality of installation.

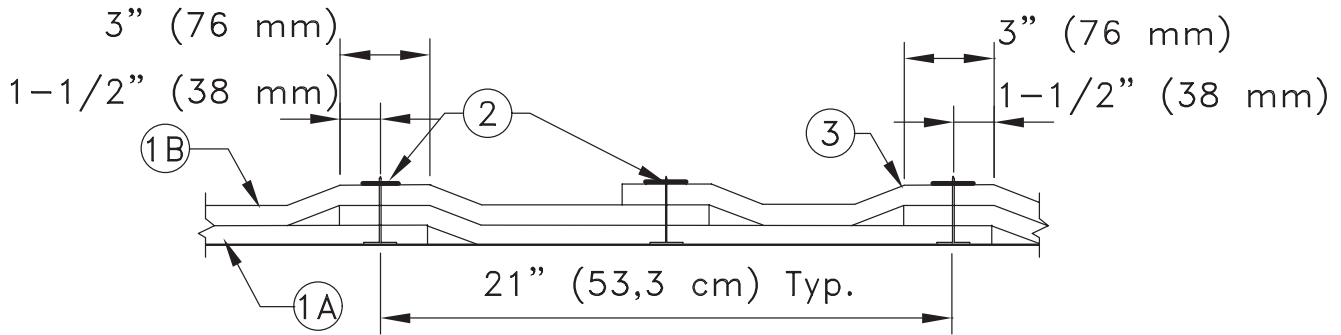
**Figure 2A**  
**3M Fire Barrier Duct Wrap 20A**  
**Commercial Kitchen Grease Duct Systems**  
**1 or 2 Hour Shaft Alternative Zero Clearance to Combustibles**  
**Telescoping Wrap Technique With Weld Pins Only**



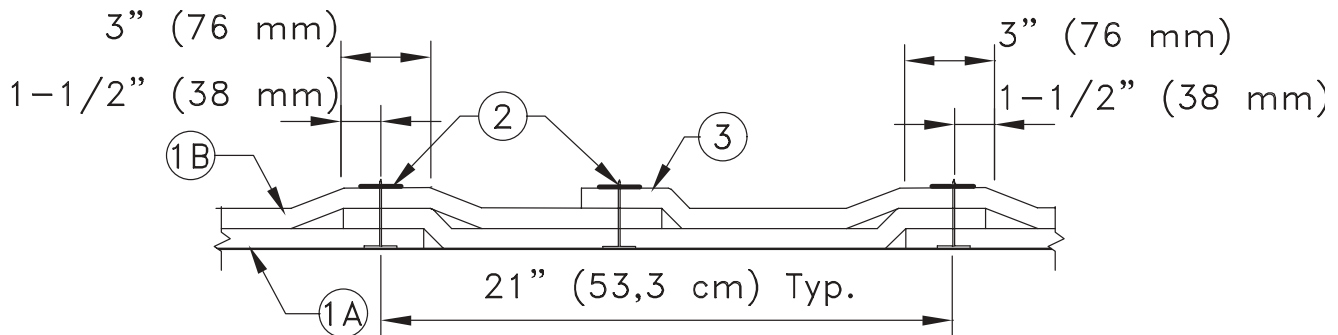
1A.	First Layer 3M Fire Barrier Duct Wrap 20A
1B.	Second Layer 3M Fire Barrier Duct Wrap 20A
2.	1-1/2 in. Square (38 mm) or 1-1/2 Dia. (38 mm) Galvanized Speed Clips
3.	3 in. (76 mm) Min. Longitudinal Overlap
4.	3 in. (76 mm) Min. Perimeter Overlap

System integrity is limited by quality of installation.

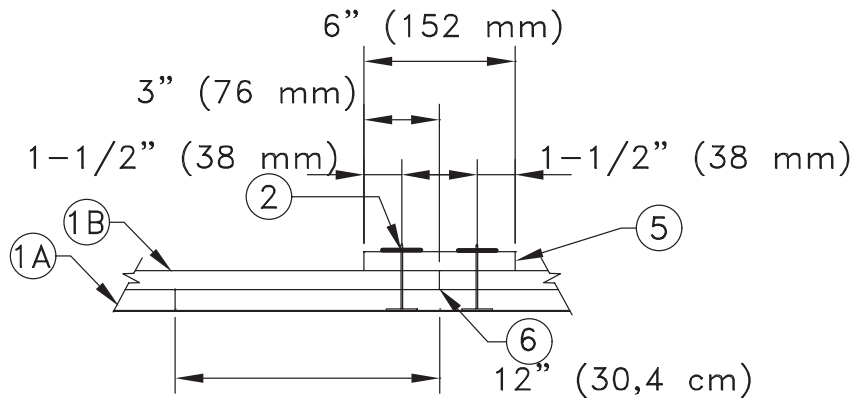
**Figure 2B Telescoping Overlap Wrap Option  
Cross Sectional View**



**Figure 2C Checkerboard Overlap Wrap Option  
Cross Sectional View**



**Figure 2D Butt Joint With Collar Option  
Cross Sectional View**

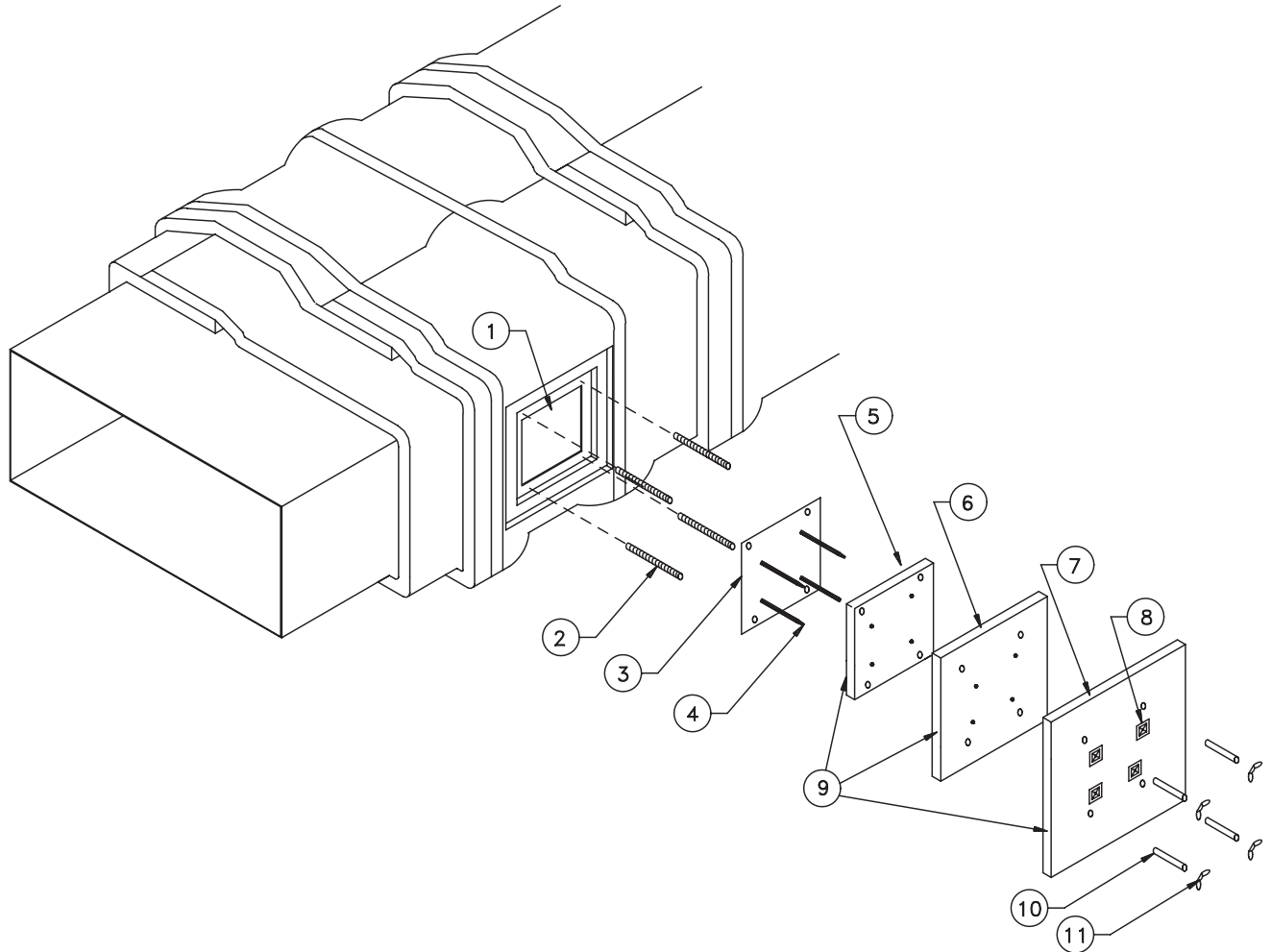


1A.	First Layer 3M Fire Barrier Duct Wrap 20A
1B.	Second Layer 3M Fire Barrier Duct Wrap 20A
2.	1-1/2 in. Square (38 mm) or 1-1/2 Dia. (38 mm) Galvanized Speed Clips
3.	3 in. (76 mm) Min. Longitudinal Overlap
4.	3 in. (76 mm) Min. Perimeter Overlap
5.	6 in. (152 mm) Wide Collar: Prefabricated 3M Fire Barrier 20A Collar
6.	Firmly Butted Joint

System integrity is limited by quality of installation.



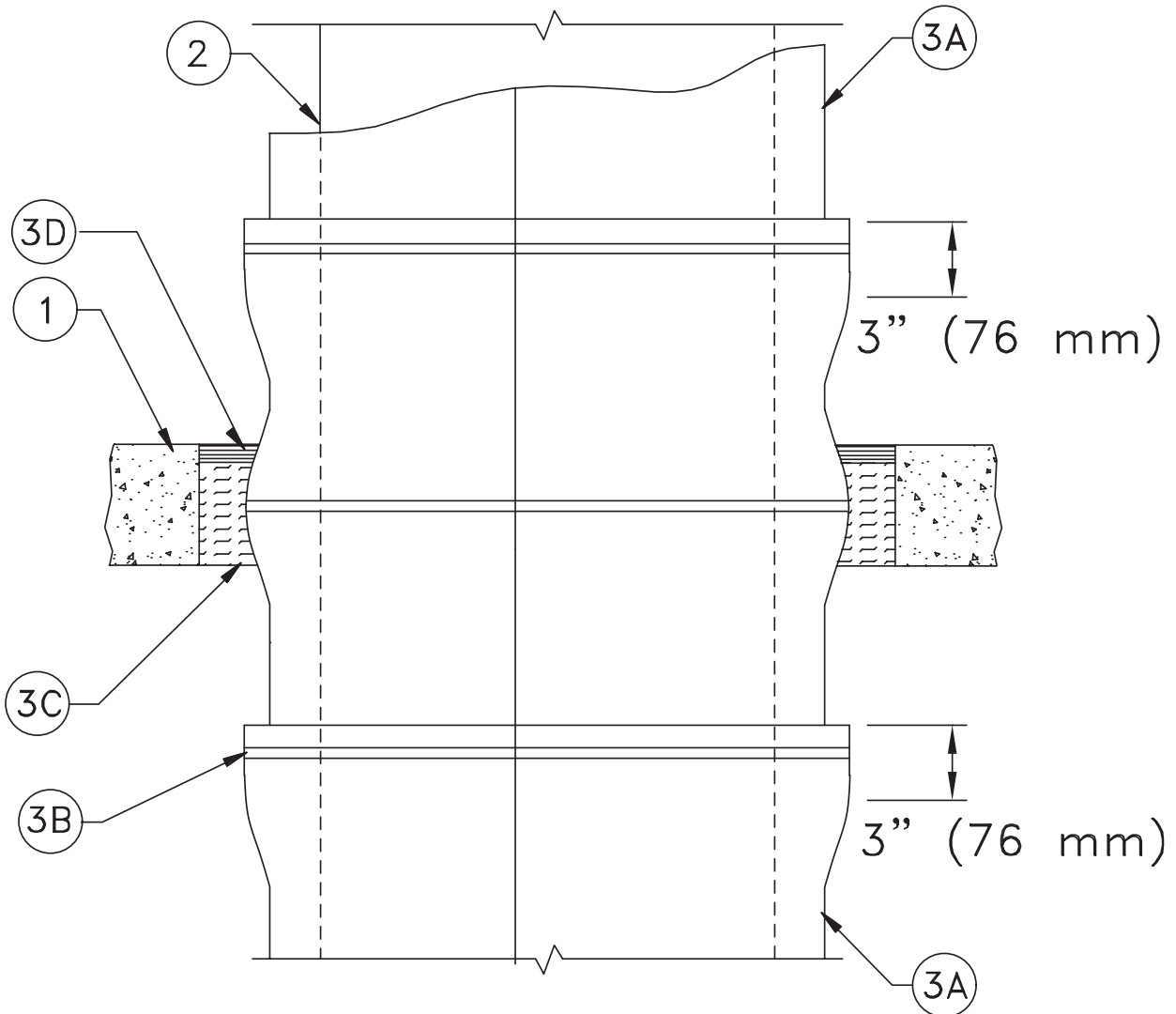
**Figure 3**  
**3M Fire Barrier Duct Wrap 20A**  
**Commercial Kitchen Grease Duct Systems**  
**1 or 2 Hour Access Door System**



1.	Access Hole
2.	1/4 in. (6 mm) Dia. All Threaded Rods
3.	Access Cover – 16 Gauge
4.	Insulation Pins – Welded
5.	First Layer 3M Fire Barrier Duct Wrap 20A Cut Same Size As Cover
6.	Second Layer 3M Fire Barrier Duct Wrap 20A with 1 in. (25mm) Overlap On All Sides
7.	Third Layer 3M Fire Barrier Duct Wrap 20A with 1 in. (25mm) Overlap On All Sides of Previous Layer
8.	Speed Clips
9.	Aluminum Tape Covering All Exposed Edges
10.	Spool Pieces For Threaded Rods
11.	1/4 in. (6mm) Diameter Wing Nuts

System integrity is limited by quality of installation.

**Figure 4A**  
**3M Fire Barrier Duct Wrap 20A**  
**Commercial Kitchen Grease Duct Systems**  
**1 or 2 Hour Through Penetration Systems**  
**4-1/2 inch (11,4 cm) Concrete Floor or Wall**



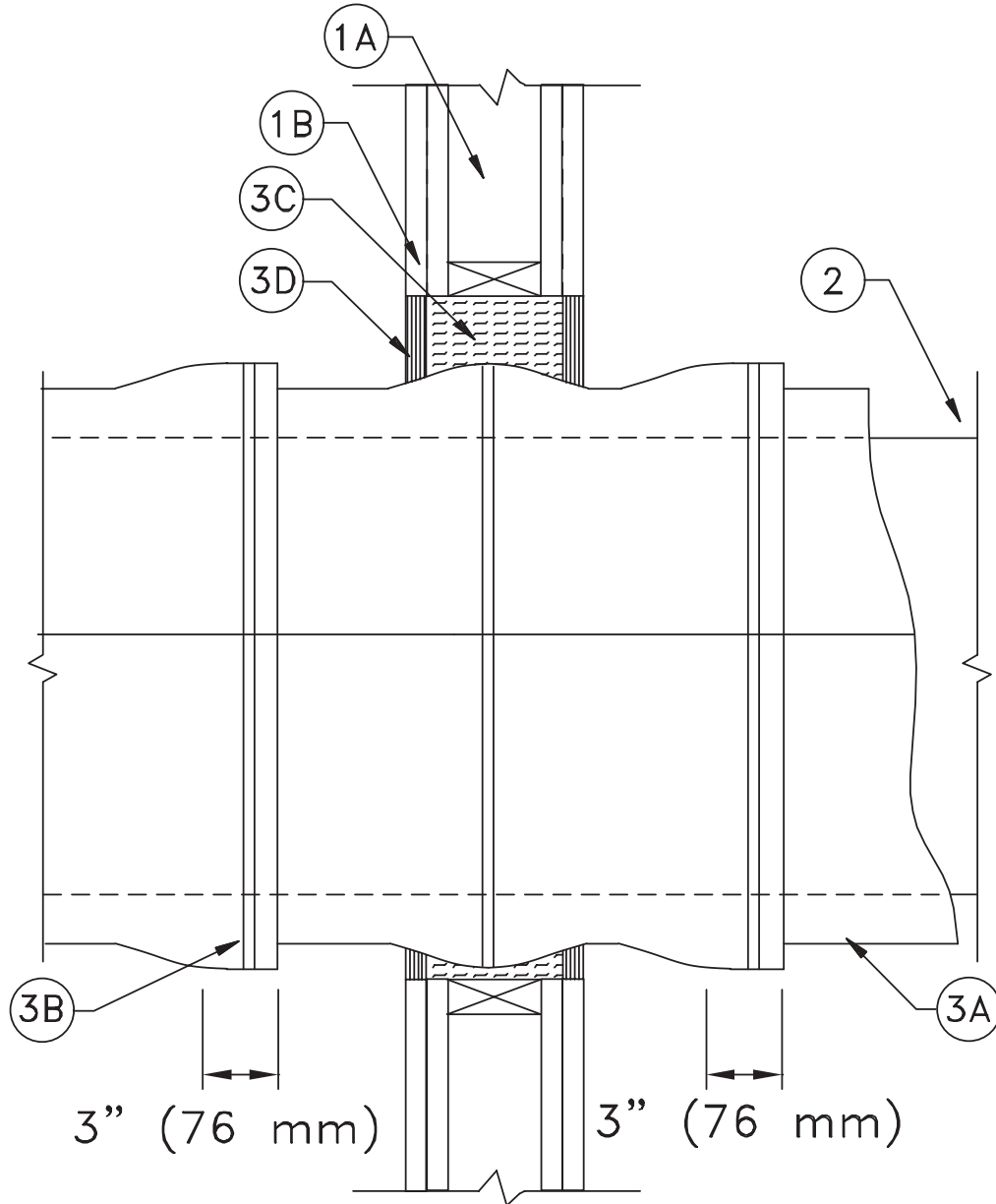
1.	Floor/Ceiling or Wall Assembly
2.	Duct
3A.	Two Layers 3M Fire Barrier Duct Wrap 20A
3B.	Banding or Pinning
3C.	Packing Material
3D.	3M Fire Barrier 1000 N/S, 1003 S/L or 2000+ Silicone Sealant For Wall Assembly Apply Sealant To Both Sides of Wall

Omega Point Laboratories, Inc.  
Through Penetration Systems

FS 560 F  
FS 562 W

System integrity is limited by quality of installation.

**Figure 4B**  
**3M Fire Barrier Duct Wrap 20A**  
**Commercial Kitchen Grease Duct Systems**  
**1 or 2 Hour Through Penetration Systems**  
**Fire-Rated Gypsum Wallboard**



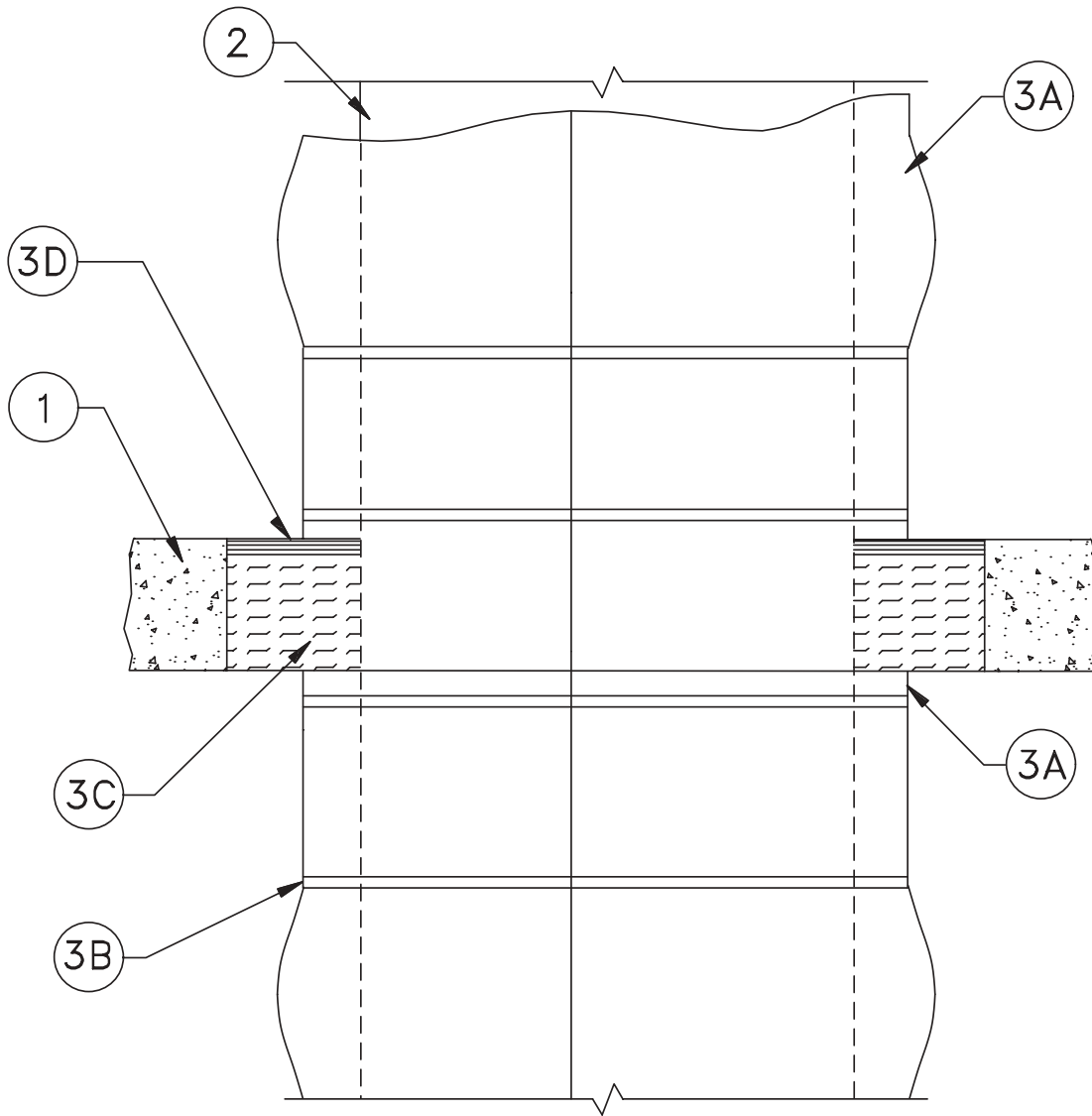
1A.	Studs
1B.	Gypsum Wallboard
2.	Duct
3A.	Two Layers 3M Fire Barrier Duct Wrap 20A
3B.	Banding or Pinning
3C.	Packing Material
3D.	3M Fire Barrier 1000 N/S or 2000+ Silicone Sealant

Omega Point Laboratories, Inc.  
Through Penetration Systems

FS 557 W  
FS 559 W

System integrity is limited by quality of installation.

**Figure 4C**  
**3M Fire Barrier Duct Wrap 20A**  
**Commercial Kitchen Grease Duct Systems**  
**1 or 2 Hour Through Penetration Systems**  
**4-1/2 inch (11,4 cm) Concrete Floor or Wall**



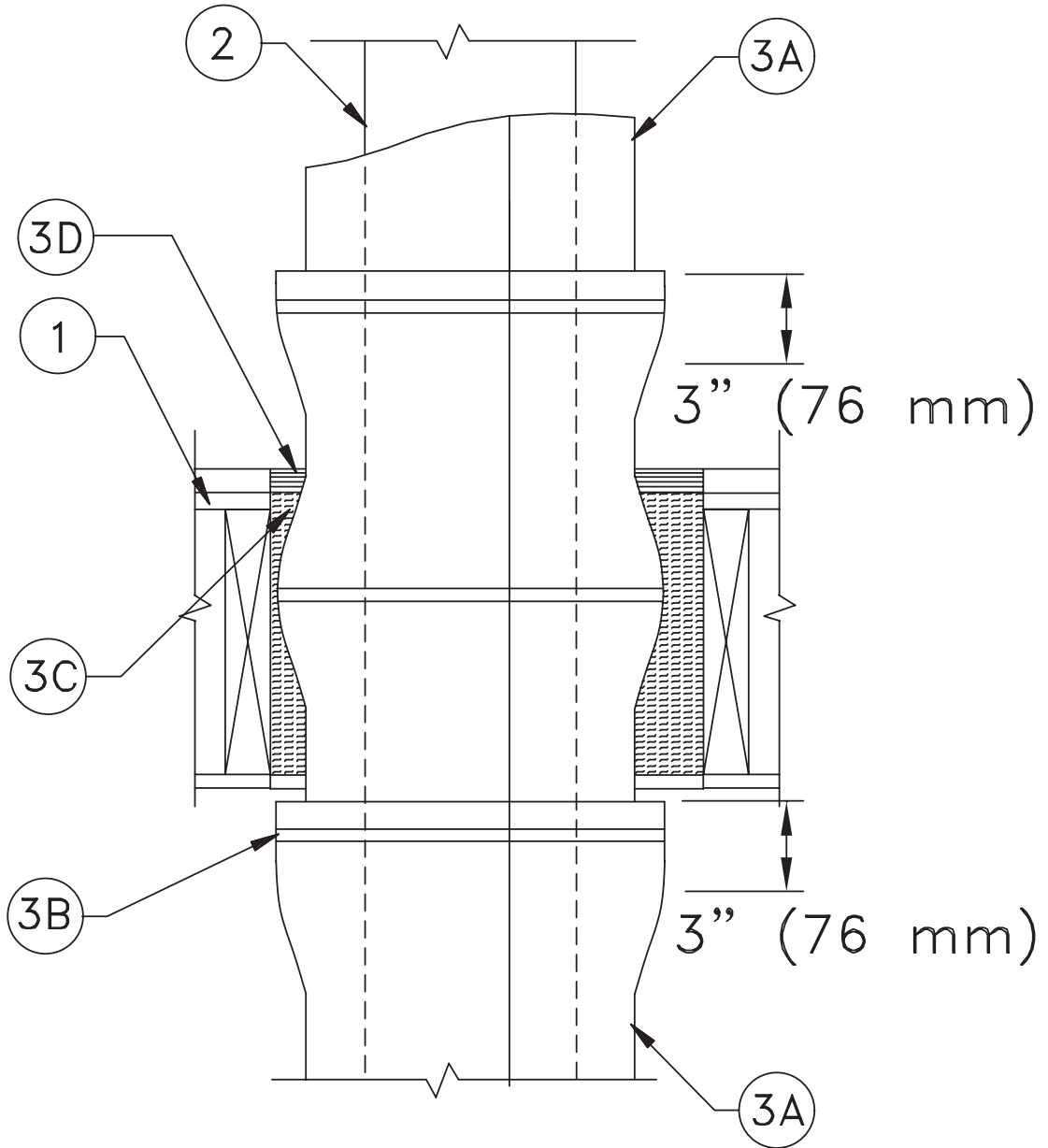
1.	Floor/Ceiling or Wall Assembly
2.	Duct
3A.	Two Layers 3M Fire Barrier Duct Wrap 20A – Terminated on Each Side of Floor or Wall Penetration.
3B.	Banding or Pinning
3C.	Packing Material
3D.	3M Fire Barrier 1000 N/S, 1003 S/L or 2000+ Silicone Sealant For Wall Assembly Apply Sealant To Both Sides of Wall

Omega Point Laboratories, Inc.  
Through Penetration Systems

FS 561 F  
FS 563 W

System integrity is limited by quality of installation.

**Figure 4D**  
**3M Fire Barrier Duct Wrap 20A**  
**Commercial Kitchen Grease Duct Systems**  
**1 Hour Through Penetration Systems**  
**Fire-Rated Wood/Gypsum - Floor/Ceiling Assembly**



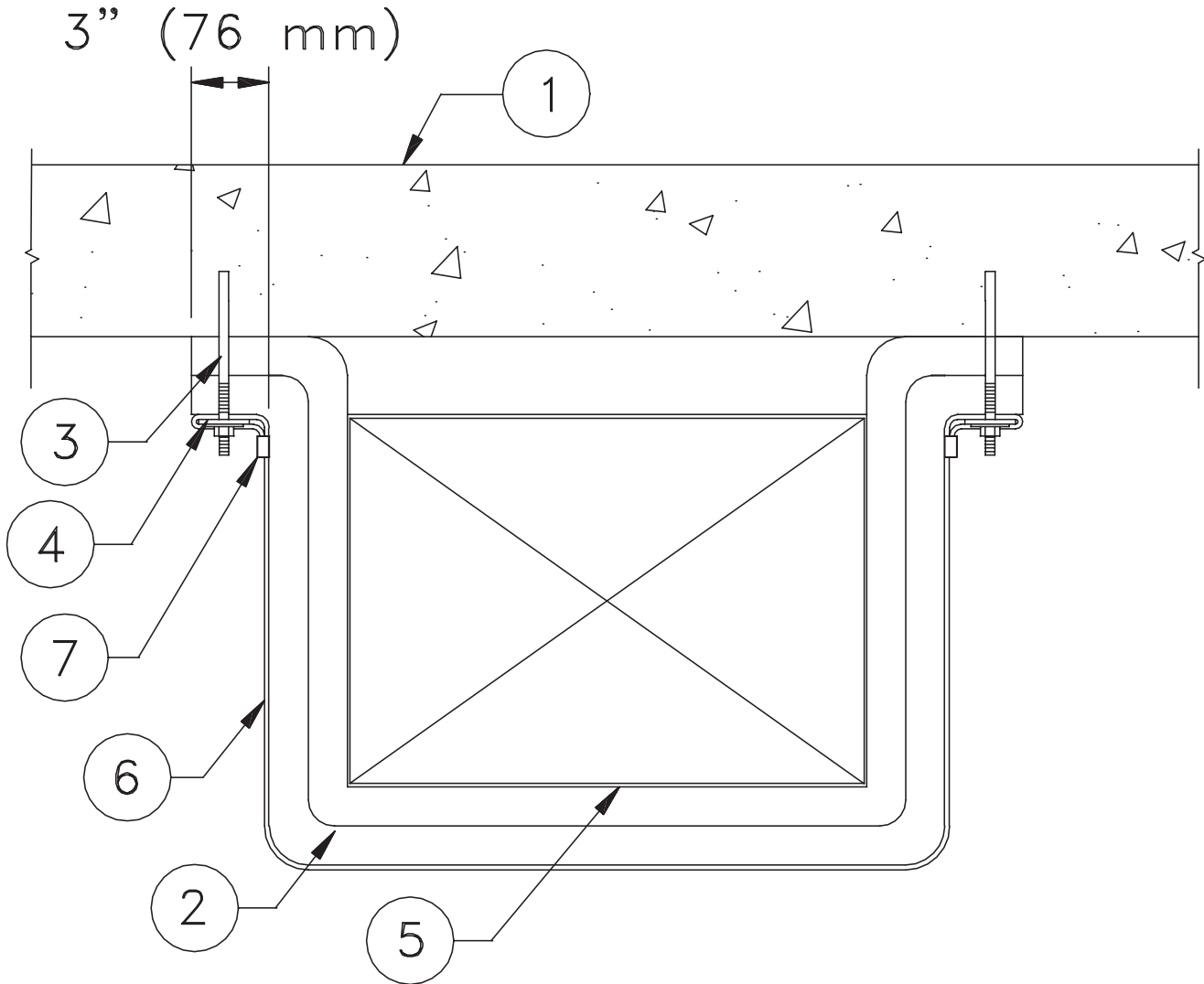
1.	Fire-rated Floor/Ceiling Assembly
2.	Duct
3A.	Two Layers 3M Fire Barrier Duct Wrap 20A
3B.	Banding or Pinning
3C.	Packing Material
3D.	3M Fire Barrier 1000 N/S, 1003 S/L or 2000+ Silicone Sealant

System integrity is limited by quality of installation.

Omega Point Laboratories, Inc.  
 Through Penetration Systems

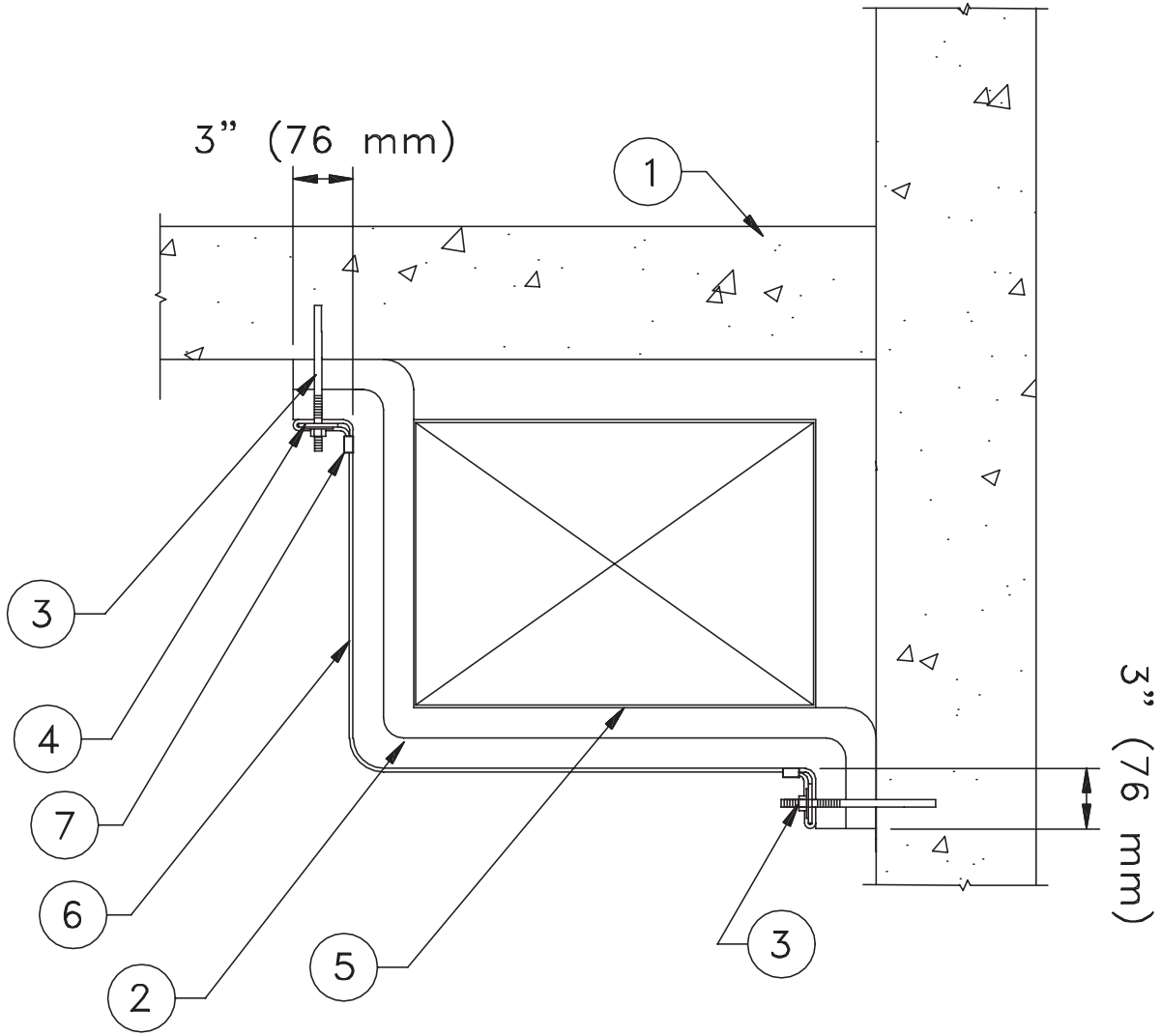
FS 558 F

**Figure 5**  
**3M Fire Barrier Duct Wrap 20A**  
**Commercial Kitchen Grease Duct Systems**  
**Suggested 1 or 2 Hour Three Sided Wrap**



1.	Concrete Slab
2.	Two Layers 3M Fire Barrier Duct Wrap 20A
3.	Concrete Fasteners - Minimum 1/4 in. (6 mm) Dia. Steel Concrete Anchors
4.	1/8 in. (3mm) Thick x 2 in.-3in. (50mm - 76mm) Wide Bar Stock Perforated 12 in. (30 cm)
O.C.	
5.	Duct
6.	Banding
7.	Banding Clips

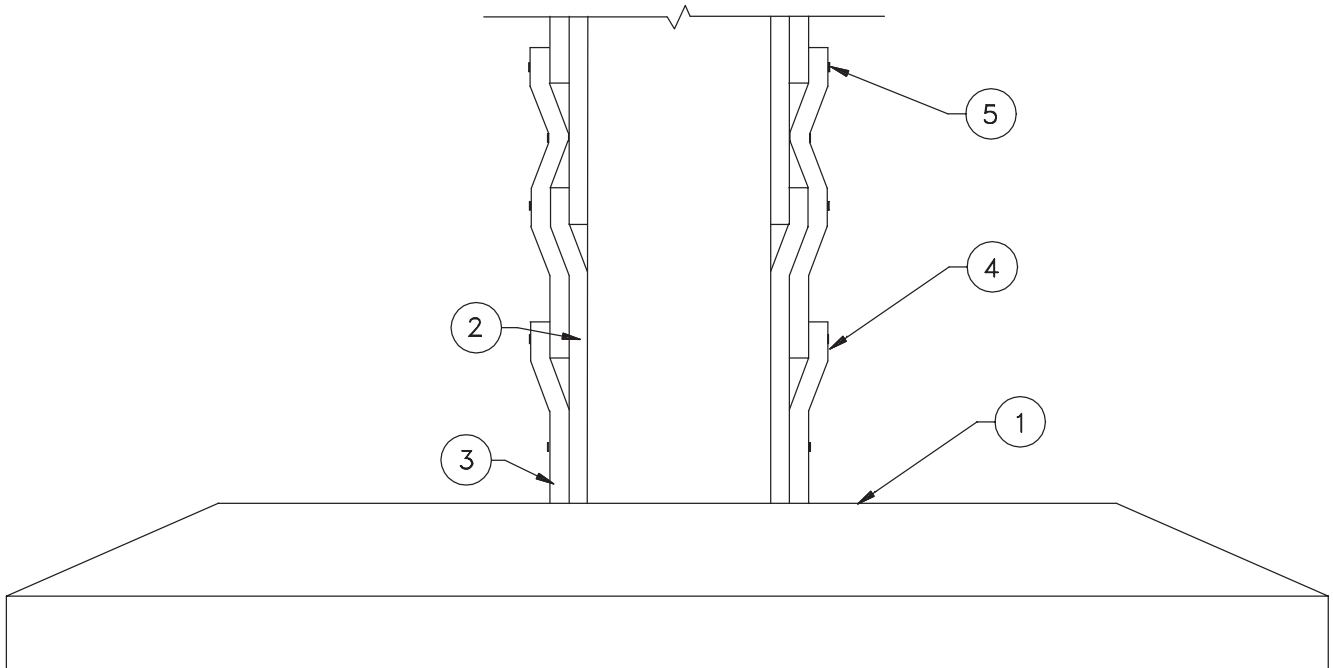
**Figure 6**  
**3M Fire Barrier Duct Wrap 20A**  
**Commercial Kitchen Grease Duct Systems**  
**Suggested 1 or 2 Two Hour Two Sided Wrap**



1.	Concrete Slab
2.	Two Layers 3M Fire Barrier Duct Wrap 20A
3.	Concrete Fasteners - Minimum 1/4 in. (6 mm) Dia. Steel Concrete Anchors
4.	1/8 in. (3 mm) Thick x 2 in.-3 in. (50 mm – 76 mm) Wide Bar Stock Perforated 12 in. (30 cm) O.C.
5.	Duct
6.	Banding
7.	Banding Clips

System integrity is limited by quality of installation.

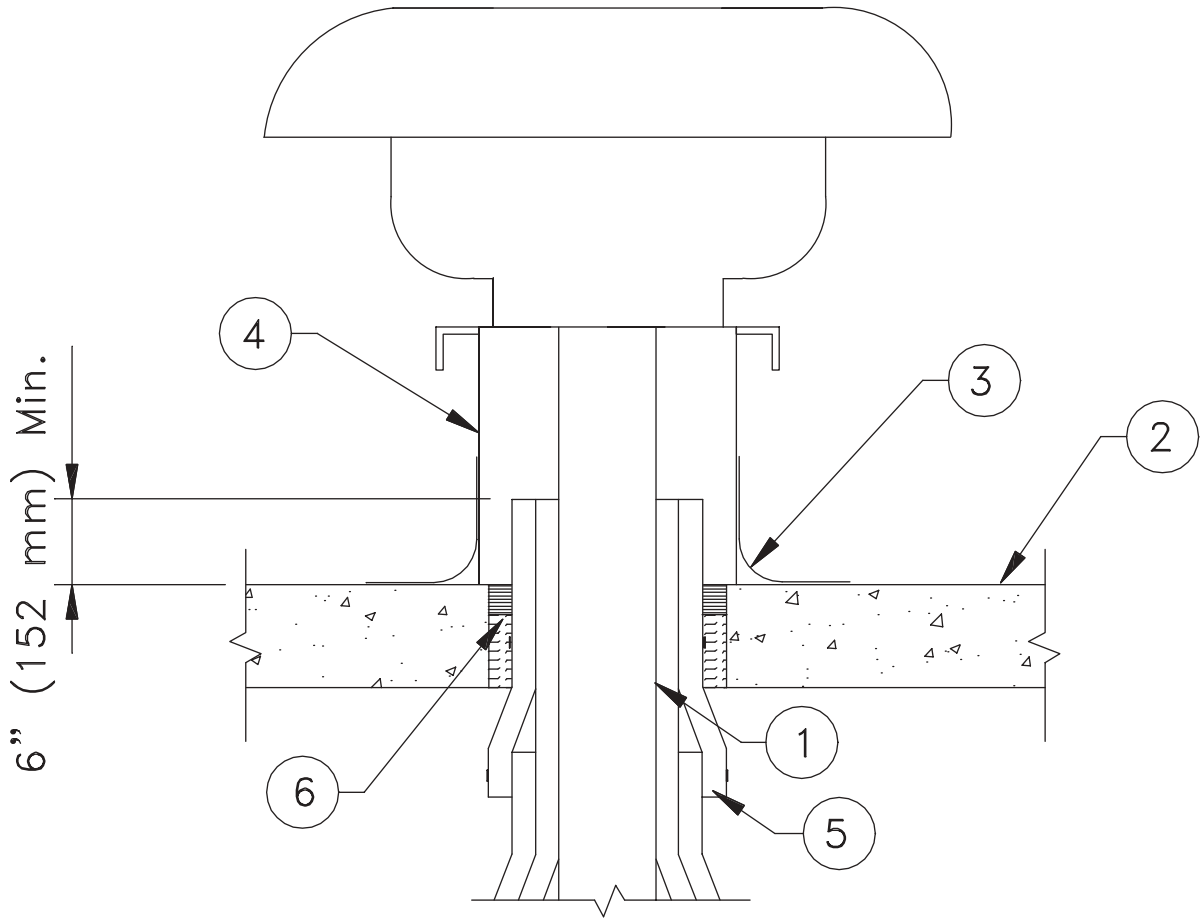
**Figure 7**  
**3M Fire Barrier Duct Wrap 20A**  
**Commercial Kitchen Grease Duct Systems**  
**1 or 2 Hour Shaft Alternative Zero Clearance to Combustibles**  
**Suggested Exhaust Hood**



1.	Hood
2.	Two Layers 3M Fire Barrier Duct Wrap 20A
3.	6 in. (152 mm) Minimum Overlap
4.	Banding

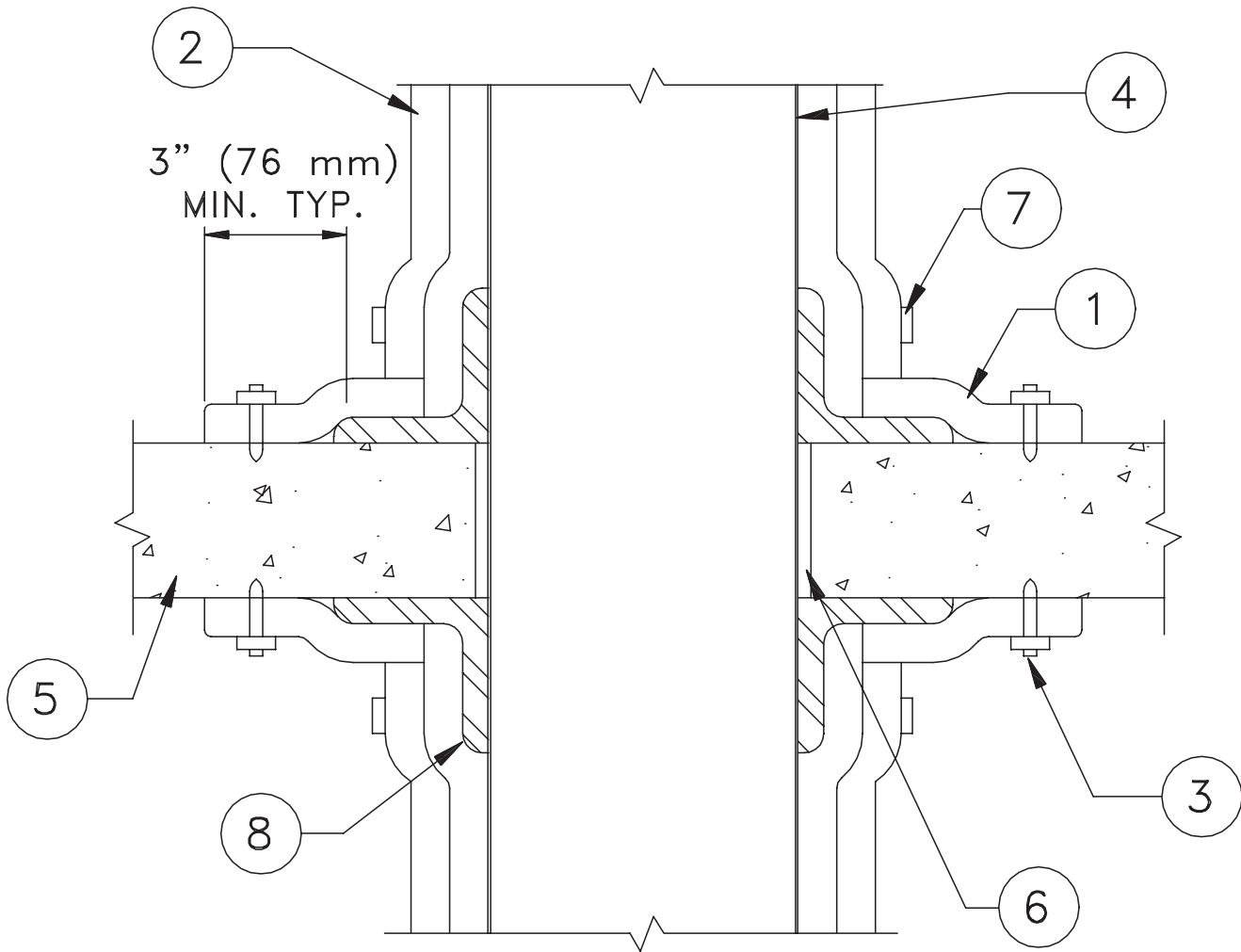


**Figure 8**  
**3M Fire Barrier Duct Wrap 20A**  
**Commercial Kitchen Grease Duct Systems**  
**1 or 2 Hour Shaft Alternative Zero Clearance to Combustibles**  
**Suggested Roof Vent**



1.	Duct
2.	Roof Assembly
3.	Roof Flashing
4.	Vent Flashing
5.	Two Layers 3M Fire BarrierDuct Wrap 20A
6.	Firestopping System for Rated Roof Assemblies Only

**Figure 9**  
**3M Fire Barrier Duct Wrap 20A**  
**Commercial Kitchen Grease Duct Systems**  
**1 or 2 Hour Shaft Alternative Zero Clearance to Combustibles**  
**Suggested Vertical Support**



1.	First Layer 3M Fire Barrier Duct Wrap 20A
2.	Second Layer 3M Fire Barrier Duct Wrap 20A
3.	Mechanical Fasteners and Washers
4.	Duct
5.	Rated Floor/Ceiling
6.	Firestopping System
7.	Banding
8.	Support Channel



**Warranty and Limited Remedy.** This product will be free from defects in material and manufacture for a period of ninety (90) days from date of purchase. **3M MAKES NO OTHER WARRANTIES INCLUDING, BUT NOT LIMITED TO, ANY IMPLIED WARRANTY OR MERCHANTABILITY OR FITNESS FOR A PARTICULAR PURPOSE.** User is responsible for determining whether the 3M product is fit for a particular purpose and suitable for user's method of application. If this 3M product is proved to be defective within the warranty period stated above, your exclusive remedy and 3M's sole obligation shall be, at 3M's option, to replace or repair the 3M product or refund the purchase price of the product.

**Limitation of Liability.** Except where prohibited by law, 3M will not be liable for any loss or damages arising from the use of this 3M product, whether direct, indirect, special, incidental or consequential, regardless of the legal theory asserted, including warranty, contract, negligence or strict liability.



**Specified Construction Products Department**

3M Center 223-2N-21  
St. Paul, MN 55144-1000  
(800) 328-1687

Printed in U.S.A.

© 3M 2001 98-0400-5055-5 (July 2001)